

## Arc Gouging Torches / Carbons

### Arc Gouging Torches

Best Welds® torches will groove, bevel, cut, gouge, pierce or flush away any kind of metal. The Best Welds® torch saves time, costs less to use and gives a better finished job than older methods such as grinding, chipping, etc.

#### GT4000

- Heavy duty yet light weight.
- 1000 AMP maximum.
- Accepts pointed carbons to 1/2".
- Accepts flat carbons to 5/8".

Gouge torch with 7' cable  
**Part No. GT61-082-008**

Gouge torch with 10' cable  
**Part No. GT61-082-009**

Gouge torch only  
**Part No. GT01-082-002**



#### Model H3

General purpose gouge torch  
**Part No. 61-062-016X**



#### Model K3

The K3 is a medium-duty torch. This torch is built for repair and maintenance jobs in areas such as mining, construction and all types of metal fabrication.

**Part No. 61-064-009X**



### GT4000 Replacement Parts

All parts are interchangeable with other industry-leading gouging torches.



Part No.	Description
GT94-476-066	Lever assembly w/screw
GT94-800-077	Spring
GT94-433-183	Insulator assembly w/screw
GT94-370-163	Handle
GT94-103-206	Torch body
GT94-632-094	Hinge pin
GT94-048-088	Upper arm
GT94-378-368	Head
GT94-170-150	Air/power connector
GT94-105-014	Insulating boot
GT94-104-016	Valve with bonnet
GT94-801-011	Valve with o-rings
GT94-710-036	O-rings only
GT94-104-012	Bonnet
GT70-084-207	Power cable 7'
GT70-084-210	Power cable 10'

### Carbons Arc Gouging Electrodes

- Designed specifically for the air carbon arc metal removal process.
- Highly resistant to breakage, heat and oxidation.
- Excellent for fast-cutting of carbon and ductile irons, aluminum, copper and other high strength and high alloys.
- Broad range of cutting applications:
  - Machining grooves for weld-joint preparation.
  - Removing hard surface metal to facilitate repair.
  - Cutting non-ferrous and other hard-to-cut metals.
  - Used in industries such as metal fabrication, foundries, ship building, construction, machine shops, transportation, salvage yards, general maintenance, etc.

#### Copper-Coated Jointed Gouging Carbons



Part No.	Size		Qty/Box
	Inches	mm	
24-064-003X	3/8 x 17	9.5 x 430	100
24-084-003X	1/2 x 17	13.0 x 430	100
24-104-003X	5/8 x 17	16.0 x 430	100
24-124-003X	3/4 x 17	19.0 x 430	100

### DC Copperclad Electrodes

- Superior Metal Removal Rate.
- Clean Cuts.
- Cooler Operation.
- Uniform Diameter.
- Excellent Arc Stability.

#### Copper-Coated Pointed Gouging Carbons



Part No.	Size		Qty/Box
	Inches	mm	
22-023-003X	1/8 x 12	3.2 x 305	100
22-983-003X	5/32 x 12	4.0 x 305	50
22-033-003X	3/16 x 12	5.0 x 305	50
22-043-003X	1/4 x 12	6.5 x 305	50
22-053-003X	5/16 x 12	8.0 x 305	50
22-063-003X	3/8 x 12	9.5 x 305	50
22-082-003X	1/2 x 14	13.0 x 355	50

## Gouging Electrodes

### Gouging Electrodes

- Excellent arc stability.
- Superior metal removal rate.
- Cool operation.
- Uniform diameter.
- Clean machine-like grooves and cuts.



### DC Jetrod® Copperclad Jointed Electrodes

Eliminates stub loss and provides continuous electrode feed especially for semi-automatic and automatic torches. Machined at each end to provide male and female fittings.

Part No.	Electrode Size	
	Inches	mm
24-052-003	5/16 x 14	7.9 x 356
24-062-003	3/8 x 14	9.5 x 356
24-082-003	1/2 x 14	12.7 x 356
24-102-003	5/8 x 14	15.9 x 356
24-122-003	3/4 x 14	19.1 x 356
24-064-003	3/8 x 17	9.5 x 432
24-084-003	1/2 x 17	12.7 x 432
24-104-003	5/8 x 17	15.9 x 432
24-124-003	3/4 x 17	19.1 x 432
24-164-003	1 x 17	25.4 x 432

### DC Copperclad Pointed Electrodes

A standard all purpose gouging electrode. Controlled copper coating improves conductivity providing more efficient, cooler operation and helps maintain electrode diameter at the point of the arc.

Part No.	Electrode Size	
	Inches	mm
22-023-003	1/8 x 12	3.2 x 305
22-983-003	5/32 x 12	4.0 x 305
22-033-003	3/16 x 12	4.8 x 305
22-043-003	1/4 x 12	6.4 x 305
22-053-003	5/16 x 12	7.9 x 305
22-063-003	3/8 x 12	9.5 x 305
22-082-003	1/2 x 14	12.7 x 356

### AC Copperclad Pointed Electrodes

Designed for use with AC power supplies. Rare earth material is added to stabilize the arc, improving the operating characteristics.

Part No.	Electrode Size	
	Inches	mm
20-033-003	3/16 x 12	4.8 x 305
20-043-003	1/4 x 12	6.4 x 305
20-063-003	3/8 x 12	9.5 x 305

### DC Plain Pointed Electrodes

General purpose electrodes without the copper coating. Used on applications where copper is considered detrimental.

Part No.	Electrode Size	
	Inches	mm
21-983-003	5/32 x 12	4.0 x 305
21-033-003	3/16 x 12	4.8 x 305
21-043-003	1/4 x 12	6.4 x 305
21-053-003	5/16 x 12	7.9 x 305
21-063-003	3/8 x 12	9.5 x 305
21-083-003	1/2 x 12	12.7 x 305
21-103-003	5/8 x 12	15.9 x 305

### DC Copperclad Flat Electrodes

Specially designed for close tolerance metal removal. Excellent for removing weld crowns, repairing or making dies, removing welded dogs and scarfing billets.

Part No.	Electrode Size	
	Inches	mm
35-099-003	3/8 x 5/32 x 12	9.5 x 4.0 x 305
35-033-003	5/8 x 3/16 x 12	15.9 x 4.8 x 305

## Angle-Arc® Manual Gouging Torches

Arcair Angle-Arc® torches are highly efficient metal removal tools for fabrication jobs in steel fabrication plants, shipyards, railroads, farms...anywhere people want to save time and money. They speed up weld removal, backgouging, edge preparation, defect repair and many other metal removal jobs. They are ideal for almost all metals with little or no deformation, because the heat input is so low.



Now a complete family of Angle-Arc® Torches to meet you everyday needs. Just pick the best torch to fits your gouging applications.

- **Natural 15° Torch Angle-** Greater operator comfort.
- **360° Swivel Cable-** Less cable twist and strain on operator.
- **Positive Grip Handle-** Greater operator feel and ease in positioning the torch.
- **Reduced Weight-** Optimum cable and torch weight to minimize fatigue.
- **High Quality Cable Hose-** Best quality cable hose offers high heat and abrasion resistance.
- **Rugged Construction-** Overall rugged construction for the harsh environment.



Part No. K2000



Part No. K3000



Part No. K4000



Part No. K5000

Part No.	Description	Accepts		Maximum AMPS	Compressed Air		
		Pointed Carbon	Flat Carbon		Pressure PSI	Flow Rate CFM	Torch & Cable Weight
K2000	Light duty	1/8" (3mm) to 1/4" (6mm)	3/8" (10mm)	450	40 (2.8kg/cm <sup>2</sup> )	8 (0.23m <sup>3</sup> /min)	3.6 lbs. (1.6kg)
K3000	Medium duty	1/8" (3mm) to 3/8" (10mm)	3/8" (10mm) 5/8" (16mm)	600	80 (5.6kg/cm <sup>2</sup> )	21 (0.60m <sup>3</sup> /min)	4.0 lbs. (1.8kg)
K4000	Heavy duty	5/32" (4mm) to 1/2" (13mm)	3/8" (10mm) 5/8" (16mm)	1000	80 (5.6kg/cm <sup>2</sup> )	28 (0.79m <sup>3</sup> /min)	5.4 lbs. (2.4kg)
K5000	Extra heavy duty	5/32" (4mm) to 5/8" (16mm)	3/8" (10mm) 5/8" (16mm)	1250	80 (5.6kg/cm <sup>2</sup> )	30 (0.85m <sup>3</sup> /min)	6.8 lbs. (3.1kg)

## Ordering Information

Part No.	Torch Only	Torch w/ 7 ft. Cable	Torch w/ 7 ft. Cable & Insulated Hook-Up Kit	Torch w/ 10 ft. Cable	Torch w/ 10 ft. Cable & Insulated Hook-Up Kit
K2000	01-046-001	61-046-006	61-046-004	61-046-007	61-046-003
K3000	01-065-001	61-065-006	61-065-002	61-065-007	61-065-003
K4000	01-082-002	61-082-008	61-082-006	61-082-009	61-082-007
K5000	01-105-001	61-105-002	N/A	61-105-003	N/A

## Angle-Arc® Manual Gouging Torch Parts

### Torch Assembly Replacement Parts

#### K2000, K3000 and K4000 Torch (K4000 Shown)

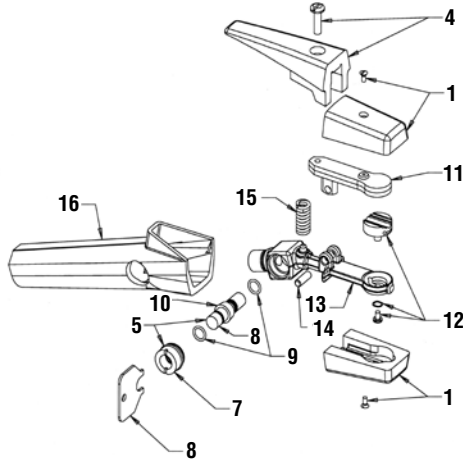

Item	Description	K2000	K3000	K4000	K5000
	Complete torch	01-046-001	01-065-001	01-082-002	01-105-001
1	Insulators and screws	94-433-193	94-433-193	94-433-183	N/A
2	Upper insulator	N/A	N/A	N/A	94-433-202
3	Lower insulator	N/A	N/A	N/A	94-433-204
4	Lever and screw	94-476-080	94-476-080	94-476-066	94-476-085
5	Valve bonnet	94-104-016	94-104-016	94-104-016	94-104-016
6	Bonnet wrench	94-960-001	94-960-001	94-960-001	94-960-001
7	Bonnet only	94-104-012	94-104-012	94-104-012	94-104-012
8	Spool and O-rings	94-801-011	94-801-011	94-801-011	94-801-011
9	O-ring (2 required)	94-710-036	94-710-036	94-710-036	94-710-036
10	Spool only	94-801-010	94-801-010	94-801-010	94-801-010
11	Upper arm	94-048-119	94-048-120	94-048-088	94-048-121
12	Head and screw	94-378-364	94-378-366	94-378-368	94-378-366
13	Torch body	94-103-233	94-103-232	94-103-206	94-103-235
14	Hinge pin	94-632-100	94-632-101	94-632-094	94-632-105
15	Spring	94-800-191	94-800-191	94-800-077	94-800-077
16	Handle	94-370-179	94-370-179	94-370-163	94-370-189

#### K5000 Torch

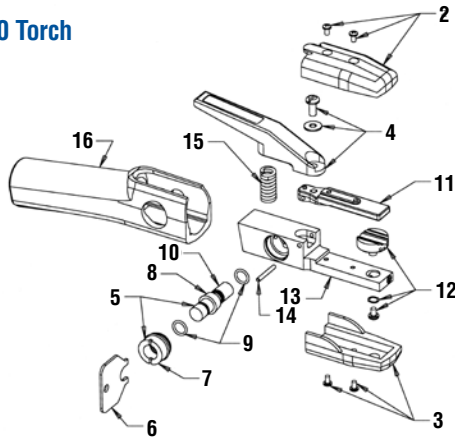

### Hook-Up Kit & Parts

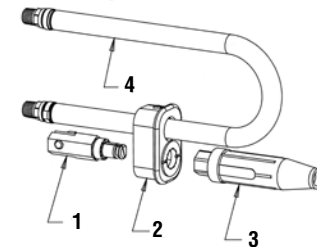

Item	Description	Part No.
	Complete hook-up kit	94-463-045
1	Male gouging connector	94-170-181
2	Cable boot cap	94-105-027
3	4-WPC-R connector	4-WPC-R
4	Pigtail air supply hose	94-396-205

### Cable Assembly Replacement Parts

#### K2000 & K3000 Cable

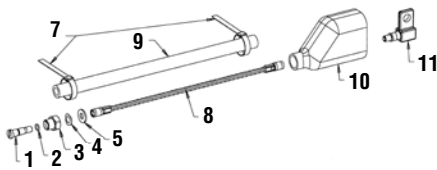

#### K4000 Cable

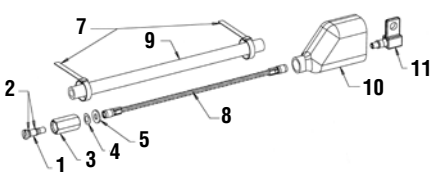

#### K5000 Cable

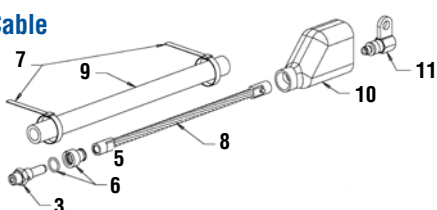

Item	Description	K2000	K3000	K4000	K5000
	7' (2.1m) cable assembly	70-088-107	70-088-107	70-084-207	70-128-507
	10' (3m) cable assembly	70-088-110	70-088-110	70-084-210	70-128-510
1	Retainer screw	94-695-054	94-695-054	94-170-182	N/A
2	O-ring	94-710-027	94-710-027	SEE ABOVE	N/A
3	Connector	94-170-178	94-170-178	SEE ABOVE	94-170-105
4	Spring washer	94-940-104	94-940-104	94-940-104	N/A
5	Flat washer	94-940-103	94-940-103	94-940-103	N/A
6	Swivel sleeve	N/A	N/A	N/A	94-784-051
7	Clamp (2 required)	98-167-010	98-167-010	98-167-010	98-167-012
8	7' (2.1m) conductor	96-130-314	96-130-314	96-130-263	96-130-061
8	10' (3m) conductor	96-130-315	96-130-315	96-130-261	N/A
9	7' (2.1m) cover	94-171-273	94-171-274	94-171-274	94-171-004
9	10' (3m) cover	94-171-274	94-171-274	94-171-274	N/A
10	Insulating boot	94-105-014	94-105-014	94-105-014	94-105-017
11	Female connector	94-170-150	94-170-150	94-170-150	94-170-087

## Straight Handle Manual Gouging Torches

The K-3 and K-5 are just two torches in a line of gouging and cutting equipment that delivers rugged reliability. The addition of superb support and complete technical backup makes Arcair the number one name in air carbon arc manual torches.

The K-Model Manual Torches are an essential part of the money-saving air carbon arc metal removal process, which melts metal with an electric arc, then blows it away with a jet of ordinary shop compressed air.

These torches are highly efficient metal removal tools for fabrication jobs in steel fabrication plants, shipyards, railroads, farms anywhere people want to save time and money. They speed up weld removal, backgouging, edge preparation, defect repair and many other metal removal jobs. They are ideal for almost all metals – with little or no deformation – because the heat input is so low.

- **Natural 15° Torch Angle-** Greater operator comfort.
- **360° Swivel Cable-** Less cable twist and strain on operator.
- **Positive Grip Handle-** Greater operator feel and ease in positioning the torch.
- **Reduced Weight-** Optimum cable and torch weight to minimize fatigue.
- **High Quality Cable Hose-** Best quality cable hose offers high heat and abrasion resistance.
- **Rugged Construction-** Overall rugged construction for the harsh environment.



Part No. OK-3



Part No. OK-5

Part No.	Description	Accepts		Maximum AMPS	Compressed Air		
		Pointed Carbon	Flat Carbon		Pressure PSI	Flow Rate CFM	Torch & Cable Weight
OK-3	Medium duty	1/8" (3mm) to 3/8" (10mm)	3/8" (10mm) 5/8" (16mm)	600	80 (5.6kg/cm <sup>2</sup> )	21 (0.60m <sup>3</sup> /min)	4.0 lbs. (1.8kg)
OK-5	Extra heavy duty	5/32" (4mm) to 5/8" (16mm)	3/8" (10mm) 5/8" (16mm)	1250	80 (5.6kg/cm <sup>2</sup> )	30 (0.85m <sup>3</sup> /min)	6.8 lbs. (3.1kg)

## Ordering Information

Part No.	Torch Only	Torch w/ 7 ft. Cable	Torch w/ 7 ft. Cable & Insulated Hook-Up Kit	Torch w/ 10 ft. Cable	Torch w/ 10 ft. Cable & Insulated Hook-Up Kit
OK-3	01-064-003	61-064-016	61-064-012	61-064-017	61-064-013
OK-5	01-104-003	61-104-007	N/A	61-104-008	N/A

## Sea Torch® Combination Torch

Equipped with 10 ft. (3.05m) cable which can be disconnected from the torch.

- Underwater cutting and welding torch with a one piece body construction.
- Fully insulated electrically for safety in normal operation.
- Bright orange for high visibility to the diver.

**Length:** 8-3/4"

**Weight:** 4.5 lbs. with cable



Part No.	Description
14-050-124	Sea Torch Complete (5/16" collet chucks)
14-050-126	Sea Torch Complete (3/8" collet chucks)

## K3 / K5 Part List

### Torch Assembly Replacement Parts

K-3 and K-5 Torch (K-5 Shown)

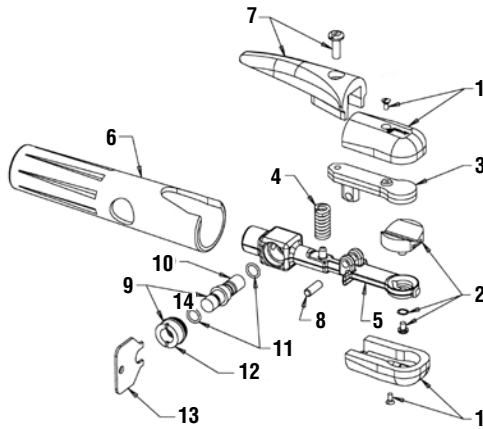

Item	Description	K-3	K-5
	Complete torch	01-064-003	01-104-003
1	Insulators and screws	94-433-118	94-433-118
2	Head & screw	94-378-368	94-378-370
3	Upper arm	94-048-087	94-048-088
4	Spring	94-800-077	94-800-077
5	Torch body	94-103-114	94-103-114
6	Handle	94-370-079	94-370-079
7	Lever and screw	94-476-034	94-476-034
8	Hinge pin	94-632-094	94-632-094
9	Valve and bonnet assembly	94-104-016	94-104-023
10	Spool and O-rings	94-801-011	94-801-021
11	O-ring	94-710-036	94-710-036
12	Valve bonnet	94-104-012	94-104-012
13	Spanner wrench	94-960-001	94-960-001
14	Always-on valve assembly	N/A	N/A
15	Torch sleeve	N/A	N/A

### Hook-Up Kit & Parts

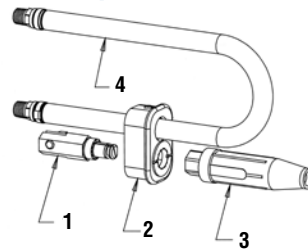

Item	Description	Part No.
	Complete hook-up kit	94-463-045
1	Male gouging connector	94-170-181
2	Cable boot cap	94-105-027
3	4-WPC-R connector	4-WPC-R
4	Pigtail air supply hose	94-396-205

### Cable Assembly Replacement Parts

#### K-3 Cable

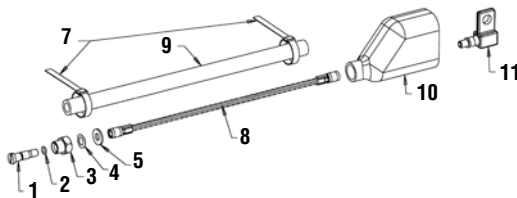

#### K-5 Cable

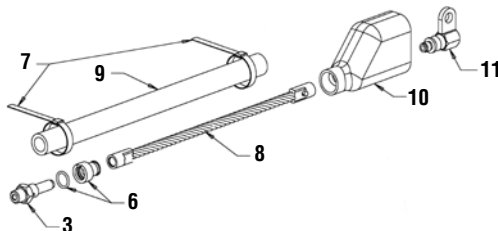

Item	Description	K2000	K3000
	7' (2.1m) cable assembly	70-088-907	70-128-507
	10' (3m) cable assembly	70-088-910	70-128-510
1	Retainer screw	94-695-054	N/A
2	O-ring	94-710-027	N/A
3	Male connector	94-170-180	94-170-105
4	Spring washer	94-940-104	N/A
5	Brass washer	94-940-103	N/A
6	Swivel sleeve	N/A	94-784-051
7	Clamp (2 required.)	98-167-010	98-167-012
8	7' (2.1m) conductor	96-130-314	96-130-061
8	10' (3m) conductor	96-130-315	N/A
9	7' (2.1m) cover	94-171-273	94-171-004
9	10' (3m) cover	94-171-274	N/A
10	Insulating boot	94-105-014	94-105-017
11	Female connector	94-170-150	94-170-087

## Water Cooled Cable Assembly and Concentric Cable Assembly

### 340° Swivel Concentric Cable Assemblies

These concentric cable assemblies supply both power and air to the Tri-Arc Torch. The 340° swivel gives the operator more freedom to maneuver the torch around the workpiece with less fatigue. It also prevents cable twisting and loosening of connections that could cause cable damage. All cables are ruggedly built to withstand the severe operating conditions present in most heavy-duty gouging environments.

**Part No. 74-143-607**- 7 ft. Cable assembly

**Part No. 74-143-610**- 10 ft. Cable assembly

#### Replacement Parts

Item	Part No.	Description
1	94-170-169	Male connector assembly
2	94-784-050	Sleeve, swivel
3	98-167-012	Clamp (2 required)
4	94-171-006	7 ft. cable cover
	94-171-140	10 ft. cable cover
5	96-130-063	7 ft. conductor assembly
	96-130-126	10 ft. conductor assembly
6	94-105-007	Insulating boot
7	94-170-095	Female connector assembly

### Extra Heavy Duty Cable Assembly

Use with the Tri-Arc Torch when current requirements exceeds 1600 AMPs. The Cable Assembly was designed to operate at a maximum current setting of 2200 AMPs. This cable is only available in a 7 foot length.

**Part No. 74-161-907**- Extra Heavy Duty Cable

#### Replacement Parts

Item	Part No.	Description
1	94-170-176	Male connector assembly
2	94-784-078	Sleeve, swivel
3	98-167-012	Band-it clamp (2 required)
4	94-171-284	7 ft. cable cover
5	96-130-286	Conductor assembly
6	94-105-019	Insulating boot
7	94-170-174	Female conductor assembly
NS	94-105-020	Sleeve, boot

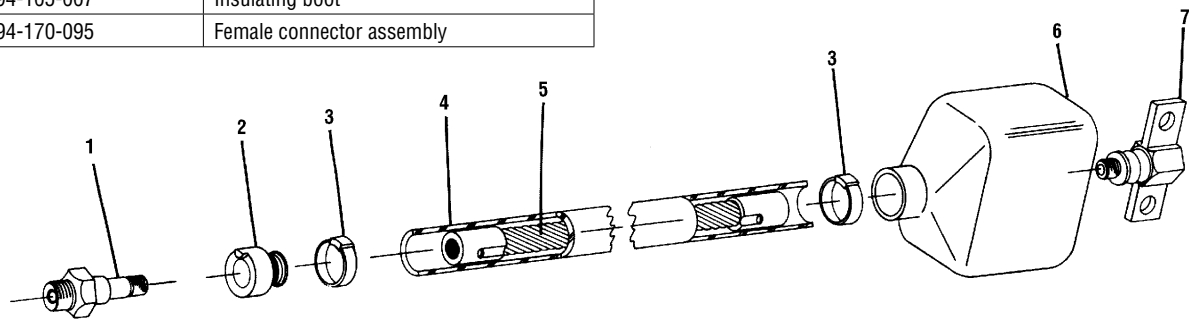

### Water-Cooled Cable Assembly

The water cooled cable was designed for heavy-duty gouging or continuous use with the Tri-Arc Torch. The cable design allows water to flow around the copper conductor causing a cooling effect. This prevents the conductor from overheating and melting the cable cover. The separate air line is attached to the male connector to supply air to the torch.

**Part No. 74-085-207**- 7 ft. Water-cooled assembly

**Part No. 74-085-210**- 10 ft. Water-cooled assembly

#### Replacement Parts

Item	Part No.	Description
1	94-170-171	Male connector assembly
2	94-170-150	Female connector assembly
3	96-130-309	7 ft. conductor assembly
4	94-171-273	7 ft. cable cover
	94-171-274	10 ft. cable cover
5	NLA	7 ft. low pressure hose
	NLA	10 ft. low pressure hose
6	NLA	Air hose fitting
7	NLA	Water hose fitting
8	94-105-014	Insulating boot
9	98-167-010	Clamp (6 required)
NS	94-105-020	Insulating sleeve

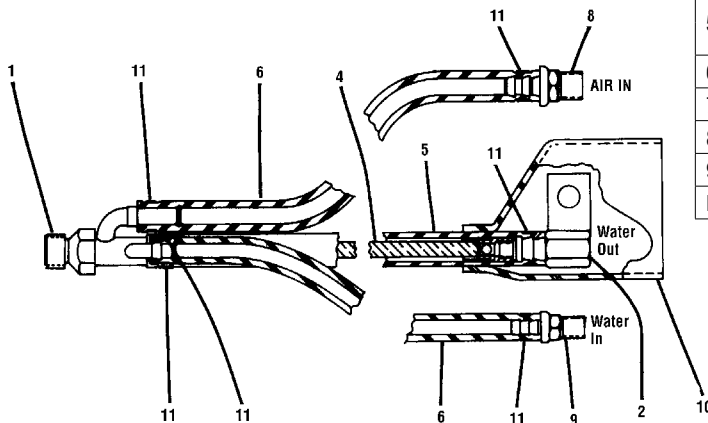

## Slice® Torch and Striker

### Slice® Torch and Striker

The Slice® Torch feeds oxygen and electrical power to a specially designed Slice® Exothermic Cutting Rod. You supply oxygen and either a 12-volt battery or a welding power supply. Either way, after turning on the oxygen and touching the carbon steel cutting rod to the grounded workpiece or a striker plate, the cutting rod ignites immediately. The Slice® Torch is sold complete, ready to connect to a welding power supply or battery and an oxygen tank.

Safety features such as a protective hand guard and spark arrestor are built into each Slice® Torch. The torch (Part No. 03-003-000) comes with a 10 ft. (3.0 m) power cable and oxygen hose. It is also available with a Cam-lok connector (Part No. 03-003-001 and 03-003-006) to make twist lock connections with available packages.

Part No.	Description
03-003-000	Slice® torch assembly (#1 cable)
03-003-001	Slice® torch assembly (#6 cable)
03-003-006	Slice® torch assembly (#10 cable)
72-012-002	Striker assembly

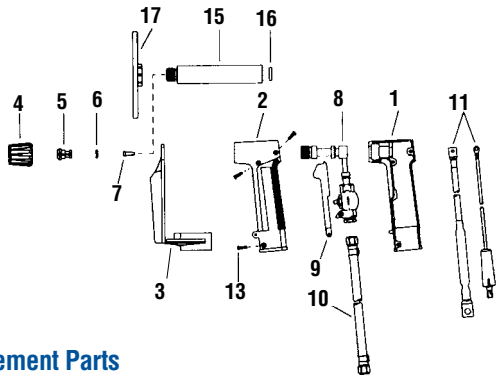

### Replacement Parts

Item	Part No.	Description
	94-370-182	Handle kit
1	94-370-166	Handle assembly, right half
2	94-370-167	Handle assembly, left half
3	94-777-109	Shield
4	94-168-022	1/4" Collet nut assembly
4	94-168-024	3/8" Collet nut assembly
5	94-158-048	1/4" Collet chuck
5	94-158-045	3/8" Collet chuck
6	94-940-109	Washer
7	94-305-009	Flashback arrestor
8	94-378-338	Head assembly
9	94-476-082	Lever assembly
10	94-396-193	Oxygen hose assembly
11	96-130-279	Cable assembly - #1
	96-130-276	Cable assembly - #6
	96-130-319	Cable assembly - #10
13*	NLA	#6-32 x 9/16" screw (3 required)
14	94-168-023	Extension - 6"
15	94-940-108	Washer
16	94-777-111	Extension shield

\*Comes with handle kits

The torch for the Slice® Cordless Striker Pack has a 10' oxygen hose, but only has a short cable pigtail for emergency use. The torch is 7.5" (19 cm) long and weighs 7 lbs. (3 kg) with the cables.

An optional Slice® Striker (Catalog No. 72-012-002) may be purchased to provide a convenient surface for igniting the rod with a 12-volt battery instead of a welding power supply.

**Note:** All Slice® torches come standard with the 1/4" Collet Chuck and Collet Nut. This includes all torches in any Slice® Pack. To utilize the 3/8" rods the user must order the 3/8" rod conversion kit which includes the 3/8" Collet Chuck and Collet Nut.

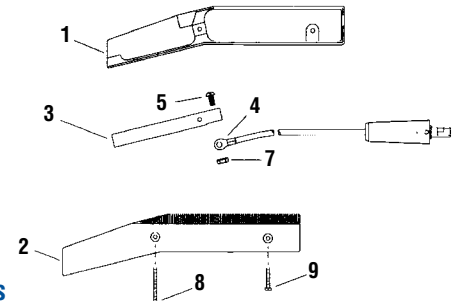

### Replacement Parts

Item	Part No.	Description
	94-370-181	Handle kit
1	94-370-168	Handle assembly (right half)
2	94-370-169	Handle assembly (left half)
3	96-070-031	Striker bar
5	NLA	#10-32 x 3/8" screw
7	NLA	#10-32 nut
8*	NLA	#6-32 x 1-1/4" screw
9*	NLA	#6-32 X 3/4" screw

\*Comes with handle kits

### SLICE® Exothermic Cutting Rods

Slice® exothermic cutting rods are designed specifically for use with Slice® cutting systems. Their unique one piece patented construction maintains the balance necessary to sustain the exothermic reaction. Once the oxygen flow is started and the rod is ignited, it will continue to burn without electrical power, as long as oxygen flow is maintained. The following is a list of the Slice® cutting rods available.

Description	Part No.	
	Flux Coated	Uncoated
<b>1/4" x 22" (7 x 559mm)</b>		
25 pcs.	42-049-002	43-049-002
100 pcs.	42-049-003	43-049-003
<b>1/4" x 44" (7 x 1118mm)</b>		
25 pcs.	N/A	43-049-005
<b>3/8" x 18" (10 x 457mm)</b>		
50 pcs.	42-049-005	43-049-007
<b>3/8" x 36" (10 x 914mm)</b>		
25 pcs.	N/A	43-049-009

## Slice® Exothermic Cutting Systems

Unlike any other cutting process used today, the Arcair® Slice® systems can cut, burn or pierce virtually any metallic, non-metallic or composite material. Our Slice® exothermic torch cuts right through hard-to-cut materials such as mild, stainless and alloy steels, cast iron, aluminum, magnesium and other non-ferrous metals, slag and refractory materials, and concrete or brick. Even if it's caked with rust, mud or other corrosion, Slice® will cut through anything. There's never been a more versatile cutting tool!

### The Slice® Utility Pack

The Slice® Utility Pack permits you to use the exothermic cutting process to cut virtually any metallic, non-metallic or composite material. The package has the basic items needed to do a cutting job packed in a rugged tool box. Just supply oxygen along with an ignition source and you are ready to cut.



Part No.	Description
63-991-026	Slice® utility pack
03-003-001	Torch assembly
72-012-002	Striker assembly
89-250-845	Instruction manual
94-134-049	Tool box
94-168-023	Collet extension assembly
94-777-111	Extension shield
96-168-035	Clamp (red)
96-168-036	Clamp (black)

### Industrial Slice® Pack

The Industrial Slice® Pack provides the versatility of exothermic cutting and accommodates a larger oxygen cylinder to extend your cutting time. The industrial cart is capable of carrying a 9" (229 mm) diameter cylinder. The Industrial Slice® Pack includes Slice® torch and striker assemblies with 10 ft./3.0m oxygen hose and power cables.



Part No.	Description
63-991-021	Slice® industrial pack
94-698-084	Oxygen regulator
03-003-001	Torch assembly
72-012-002	Striker assembly
43-049-002	1/4" cutting rods (qty 25)
94-168-023	Collet extension assembly
94-777-111	Extension shield
96-168-035	Clamp assembly (red)
96-168-036	Clamp assembly (black)
89-250-845	Instruction manual

### Slice® Cordless Striker Pack

The Slice® Cordless Striker Pack is the latest addition to the complete line of exothermic cutting equipment. The Slice® Cordless Striker uses two small lead-acid batteries to supply a current surge sufficient enough to ignite both the 1/4" and 3/8" bare Slice® Cutting Rods.

You no longer need the cables that run from a torch and striker to the battery. All of this has been put in the hand held striker igniter. When it is time to recharge just insert the igniter into one of the receptacles on the recharging unit. The red light will come on indicating the unit is charging. When the green light comes on the igniter is recharged and ready to go. The recharging unit is capable of charging two igniters at a time, in less than four hours.



Part No.	Description
63-991-032	Slice® pack
94-134-047	Tool box
03-003-008	Slice® torch assembly
72-012-007	Cordless striker igniter
96-076-034	Recharging unit
96-076-030	Igniter and recharging unit
94-168-023	Collet extension assembly
94-777-111	Collet extension shield
43-049-002	1/4" uncoated rods (25 required)
89-250-845	Instruction manual
72-012-007	Striker igniter parts list
94-370-187	Cordless striker power cell

## Slice® Torches and Packs

### Slice® Battery Pack

The Slice® Battery Pack comes in a rugged tool box. As with the Utility Pack, you get all the basic items needed to do a cutting job such as torch, striker and rods. Also included in the Battery Pack is a 12-Volt rechargeable Slice® Battery Box Assembly.



Part No.	Description
63-991-003	Slice® battery pack, 120 VAC/60HZ
94-991-007	Slice® battery pack, 220 VAC/50HZ
43-049-002	1/4" Cutting rods (quantity: 25)
89-250-857	Literature pack
96-076-021	Battery box assembly
94-134-047	Tool box
72-012-002	Striker assembly
03-003-006	Torch assembly
94-168-023	Collet extension assembly
94-777-111	Extension shield
96-130-297	Charging cable, 120 VAC/60HZ
96-130-296	Charging cable, 220 VAC/50HZ
94-173-016	Coupling
89-250-845	Instruction manual

### Slice® Equipment Product Line Parts List

Description	Utility Pack	Battery Pack		Cordless Striker Pack		Industrial Pack
		120 VAC	220 VAC	120 VAC	220 VAC	
Complete unit	63-991-026	63-991-003	63-991-007	63-991-032	63-991-033	63-991-021
Tool box, case, cart	94-134-049	94-134-047	94-134-047	94-134-047	94-134-047	92-090-202
Torch	03-003-001	03-003-006	03-003-006	03-003-006	03-003-006	03-003-001
Striker	72-012-002	72-012-002	72-012-002			72-012-002
Cordless igniter				72-012-007	72-012-007	
Extension	94-168-023	94-168-023	94-168-023	94-168-023	94-168-023	94-168-023
Shield	94-777-111	94-777-111	94-777-111	94-777-111	94-777-111	94-777-111
Clamp (red)	94-168-035					96-168-035
Clamp (black)	94-168-036					96-168-036
Rods, 1/4" x 22"		43-049-002	43-049-002	43-049-002	43-049-002	43-049-002
Battery box assembly		96-076-021	96-076-021	96-076-021	96-076-021	
Charging cable		96-130-297	96-130-296			
Battery charger				96-076-034	96-076-036	96-156-003
O <sub>2</sub> regulator assembly						94-698-084
O <sub>2</sub> cylinder 55 cu./ft.						
<b>Accessories</b>						
3/8" Conversion kit	94-463-032	94-463-032	94-463-032	94-463-032	94-463-032	94-463-032
3/8" Collet chuck	94-158-045	94-158-045	94-158-045	94-158-045	94-158-045	94-158-045
Gloves	94-351-002	94-351-002	94-351-002	94-351-002	94-351-002	94-351-002
<b>Harness Assembly</b>						
10' Cable/hose extension	96-130-294	96-130-294	96-130-294	96-130-294	96-130-294	96-130-294
O <sub>2</sub> regulator assembly	94-698-084	94-698-084	94-698-084	94-698-084	94-698-084	94-698-084
<b>O<sub>2</sub> Cylinder 55 cu./ft.</b>						
Oxygen auxiliary case	94-134-046	94-134-046	94-134-046	94-134-046	94-134-046	94-134-046
Extension/shield assembly	94-287-013	94-287-013	94-287-013	94-287-013	94-287-013	94-287-013
<b>Repair Parts</b>						
Replacement battery		96-076-018	96-076-018			
Battery box assembly		96-076-022	96-076-023			